

## Revision Sheet for Chapters 2, 7, 14, 8 and 5

### Objectives:

- To review the material covered in chapter 2, 7, 14, 8 and 5.

### Chapter 2: Expressions

1) Simplify:

$3a + 4b - 2a - 4b + 7$	$5(a + 2b) - 3(2a + b)$	$4ab + 3a + 6b - 8ab$
$15y^2 + 13y + 10y - 16y^2$	$2y^2z + 9yz + 2zy - 11zy^2$	$2x(2x - 4) + 5(3x^2 - 4x)$

2) Write an expression for the perimeter and the area of the shape below.

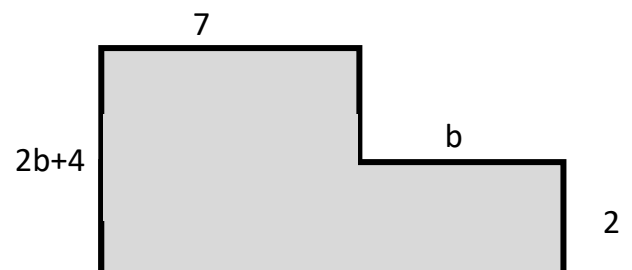

3) Write an expression for the change you receive from paying \$30 after purchasing 4 books costing "d" dollars each.

4) Write using algebra: I think of a number "x", add 5 to it then halve it.

5) Factorize:

$6kg - 3lg + mg$	$10ab - 2ac + 5da$	$12y^2 + 8y$
$2\pi r^2 + 2\pi r$	$20x^4 + 10x^3 - 4x^2$	$28axy + 7abx - 14xca$
$24k^2m^2n - 48k^2m^2n^2$	$24p^4q^3 - 8p^3q - 10p^2q^2$	$4x^3y^2 - 8x^3y - 10x^3y^2$  <b>(Hint: simplify first)</b>

6) If  $a = 4$ ,  $b = -3$ ,  $c = -2$  and  $d = 5$ , find the value of:

$-a - b - c - d$	$2b - 3c + 3d$	$3a(b - 2c)$
$\frac{abd}{c}$	$\frac{7b - 3c}{2d + 4}$	$4c^3 - d - 2b^2$

## Chapter 7: Equations, formulae and inequalities

1) Solve.

$4t + 1.5 = 13.5$	$3a - 10 = -25$
$5x = 65$	$7 - 2x = 21$
$\frac{x}{3} - 8 = 16$	$\frac{x}{6} = 4$
$8x - 15 = 5x - 6$	$7(p + 2) = 5(p + 6)$
$4x + 2(x + 2) - x = 2x + 9$	$9(2x - 4) + 20 = 10x + 8$
$\frac{x + 2}{3} = -4$	$\frac{x - 5}{2} + 7 = 10$

2) For the below questions, **first** write an equation, **then** solve it.

(i) The sum of two consecutive whole numbers is 45. What are the numbers?

(ii) Find the length of a rectangle, if the width is 4.1 cm and the perimeter is 22.4 cm.

(iii) Tia is 4 years younger than her brother Omar. The sum of their ages is 34. What are their ages?

(iv) The perimeter of the equilateral triangle below is 63. What is the length of each side?

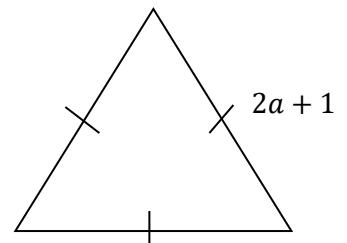

3) Using  $s = ut + \frac{1}{2}at^2$ , find "u" if  $s = 27$ ,  $t = -3$ ,  $a = 2$ .

4) Use the formula  $m = \frac{5K}{8}$  to convert 32 km into miles.

5) Rearrange the formula to make the letter in brackets the subject.

$x - 4 = y$ (x)	$g = 2m + c$ (m)	$c = 5(a + b)$ (b)
$\frac{abd}{e} = c$ (d)	$T = 4e - 5f$ (e)	$S = \frac{4}{5}m - 9$ (m)

6) Draw a function machine to show how to find " $v$ " starting with " $t$ ", using the formula  $v = u + at$ .

7) Represent these inequalities on a number line.

a.  $x > 7$



b.  $-3 \leq x < 5$



c. What is the largest integer that " $x$ " could be in the inequality  $x < 10$ .

d. Write down all the integers that satisfy the inequality  $-2 < x \leq 9$

## Chapter 14: Function and graphs

1) Complete the mapping diagrams:

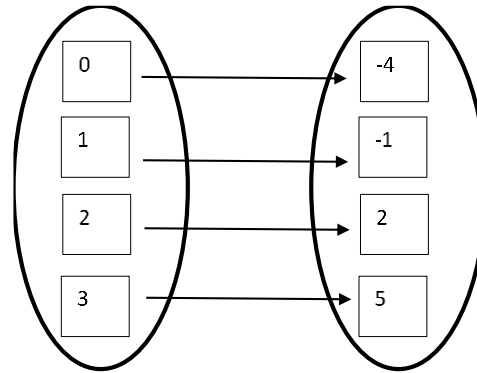
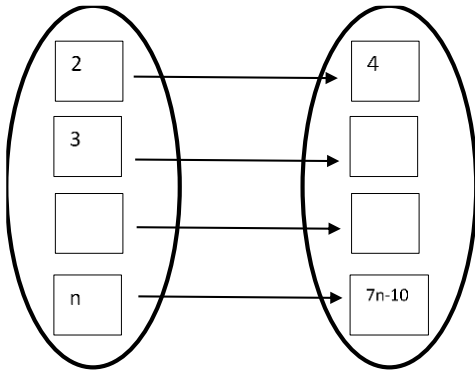

**Function:**  
 $\times$   -

2) For the graph below, do the following:  
 a. List the set of coordinates shown.

b. What rule has been used for the mapping?

c. Draw a function machine that will produce this mapping.

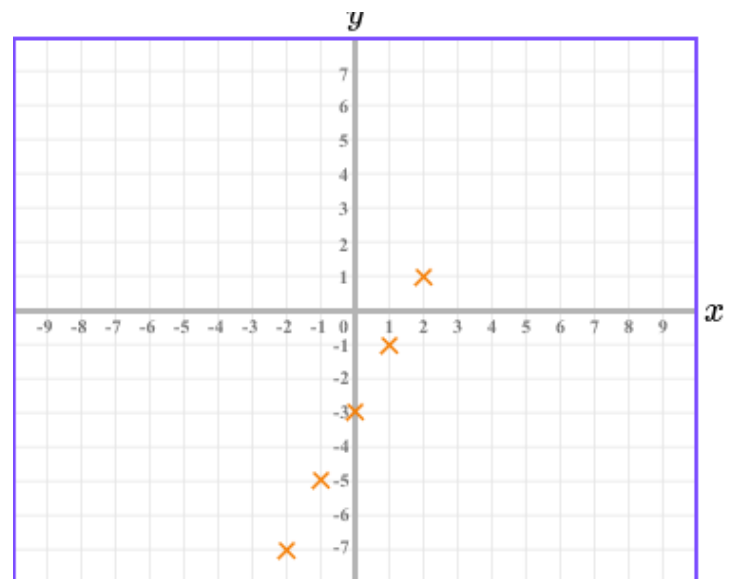



- 3) For the inputs  $-2, -1, 0, 1, 2$ , draw a graph of the mapping of the  $x$ -coordinate to the  $y$ -coordinate using:  $x \rightarrow 3x - 1$ . Join the five points with a straight line.

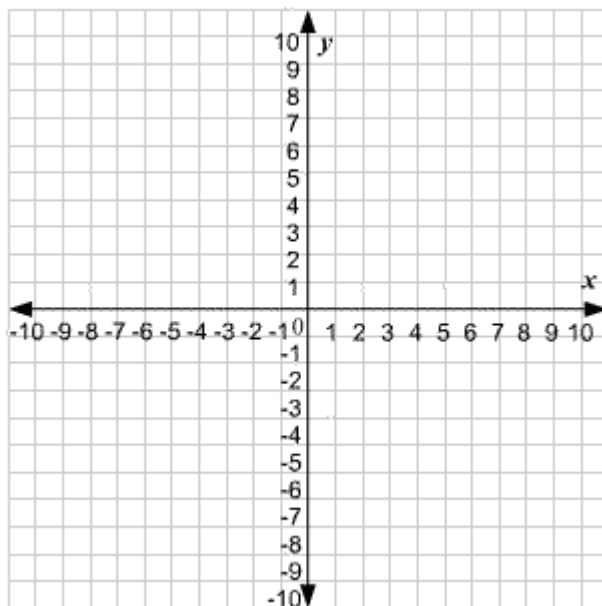

- 4) For the equations below, write down the value of:

a) the gradient,  $m$

b) the Y-intercept,  $c$

i.  $y = 3x - 4$  ( $m =$  ,  $c =$  )

ii.  $y = 7 - 2x$  ( $m =$  ,  $c =$  )

iii.  $y = -x - 1$  ( $m =$  ,  $c =$  )

iv.  $y = 2x$  ( $m =$  ,  $c =$  )

v.  $y = \frac{3}{4}x - 9$  ( $m =$  ,  $c =$  )

5) Sort these lines into two groups shown in the table:

$$y = 4x - 5$$

$$y = 7 - x$$

$$y = -2x + 3$$

$$y = \frac{2}{3}x + 1$$

$$y = -1 + 7x$$

Line sloping upwards	Line sloping downwards

6) Which of these points lie on the line  $y = 5 - 4x$ , show your work:

(1, 1)

(-2, 13)

(0, 4)

(3, -7)

(4, 21)

(-3, 17)

# Chapter 8: Geometry

1) Find the missing angles, show all your work and give reasons for your answers.

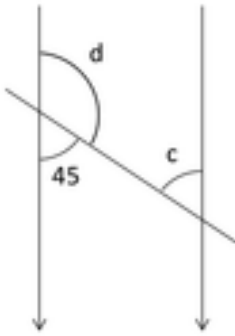

$c =$  \_\_\_\_\_  
Reason: \_\_\_\_\_

$d =$  \_\_\_\_\_  
Reason: \_\_\_\_\_

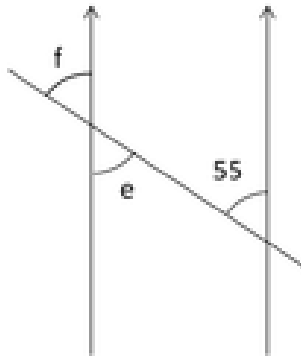

$e =$  \_\_\_\_\_  
Reason: \_\_\_\_\_

$f =$  \_\_\_\_\_  
Reason: \_\_\_\_\_

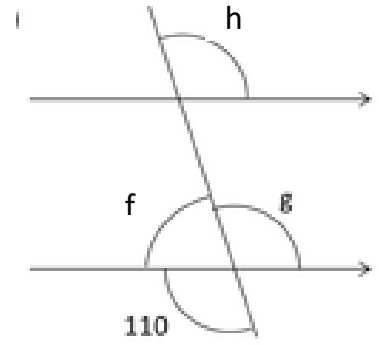

$f =$  \_\_\_\_\_  
Reason: \_\_\_\_\_

$g =$  \_\_\_\_\_  
Reason: \_\_\_\_\_

$h =$  \_\_\_\_\_  
Reason: \_\_\_\_\_

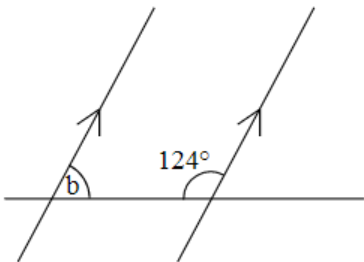

$b =$  \_\_\_\_\_  
Reason: \_\_\_\_\_

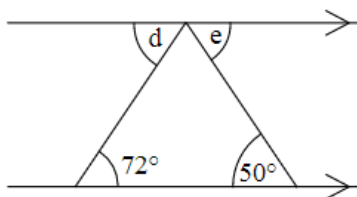

$d =$  \_\_\_\_\_  
Reason: \_\_\_\_\_

$e =$  \_\_\_\_\_  
Reason: \_\_\_\_\_

2) For the shapes below, find the missing angles, show all your work.

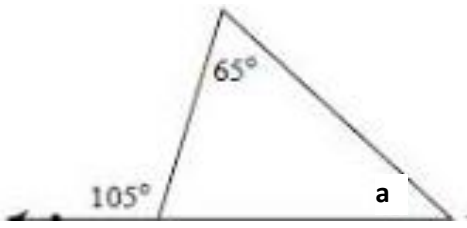

a = \_\_\_\_\_

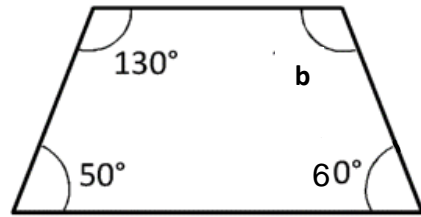

b = \_\_\_\_\_

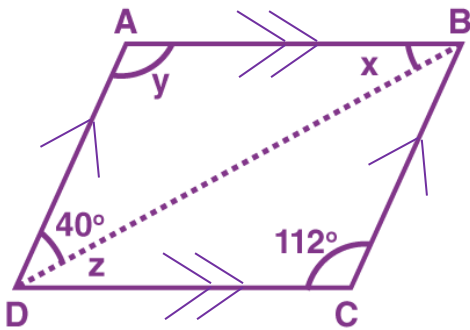

X = \_\_\_\_\_

Y = \_\_\_\_\_

Z = \_\_\_\_\_

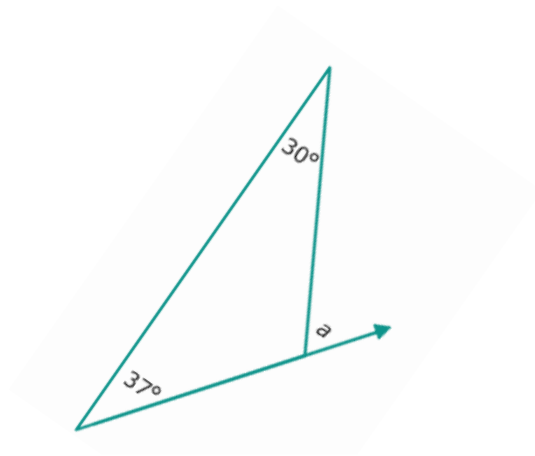

a = \_\_\_\_\_

# Chapter 5: Area, perimeter and volume

1) Fill in the empty boxes:

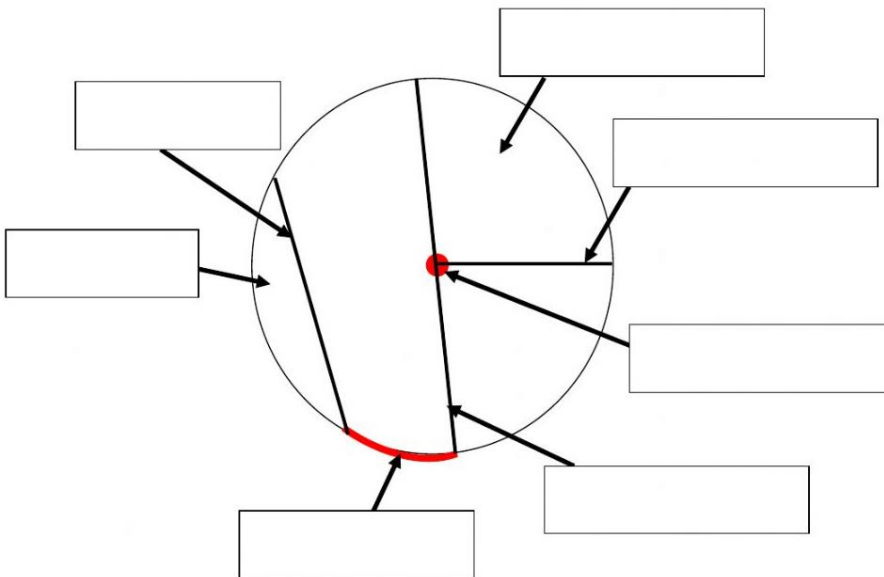

- radius
- arc
- center
- chord
- sector
- segment
- diameter

2) Find the circumference of the circles below:

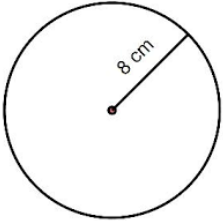
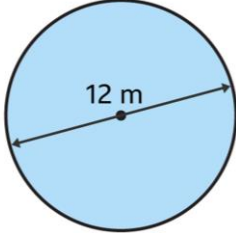
	
---	--

3) Find the perimeter of the shapes below:

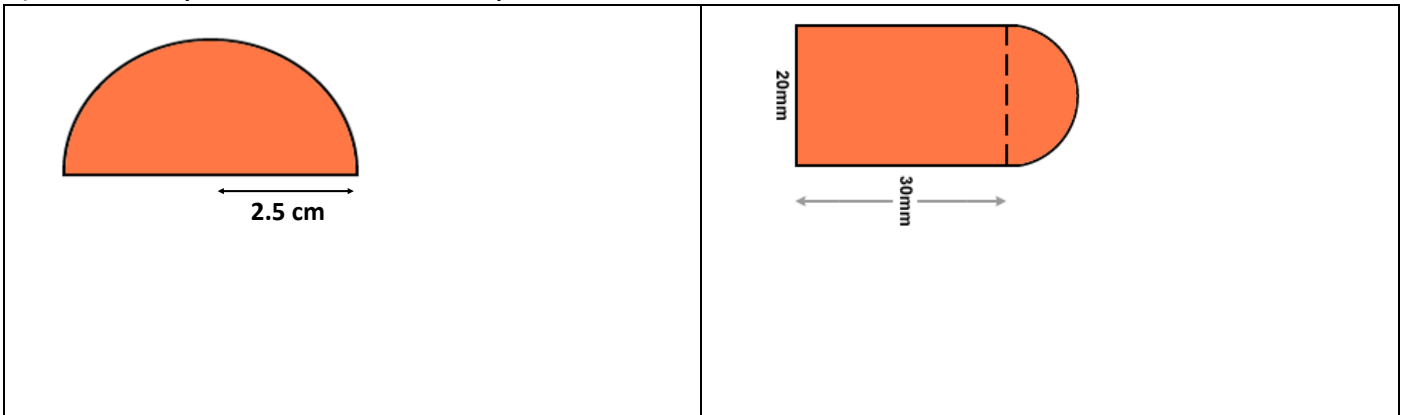

4) Find the area of the parallelograms below:

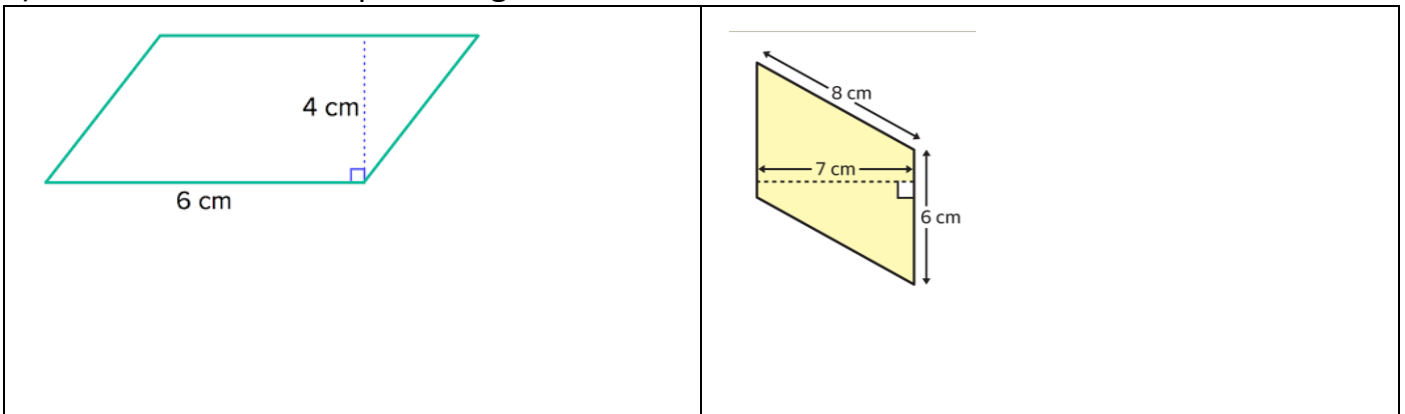

5) Complete the table for *Parallelograms*:

	Base (m)	Height (m)	Area (m <sup>2</sup> )
1	3.2		25.6
2		9	191.7