

2 Sodium hydroxide solution reacts with carbon dioxide in the air and should be standardised before use. Ethanedioic acid may be used for this standardisation.

(a) A standard solution of ethanedioic acid, $(\text{COOH})_2$, is prepared.

- 2.40 g of solid ethanedioic acid is dissolved in approximately 100 cm^3 of deionised water in a beaker.
 - The solution is transferred into a 250.0 cm^3 volumetric flask and made up to the mark with deionised water.
- (i) Give a possible reason why any solution remaining in the beaker is washed into the volumetric flask before making up to the mark.

(1)

So no solution is left behind.

(ii) Calculate the concentration of this standard solution of ethanedioic acid in mol dm^{-3} .

Give your answer to an appropriate number of significant figures.

[Molar mass of ethanedioic acid = 90.0 g mol^{-1}]

(2)

$$n = \frac{2.4}{90} = 0.027 \text{ mol}$$

$$M = \frac{0.027}{0.25} = 0.108 \text{ mol dm}^{-3}$$

(b) A **different** standard solution of ethanedioic acid is used to determine the concentration of a sodium hydroxide solution J.

Procedure

Step 1 A burette is rinsed with deionised water.

Step 2 The burette is then rinsed with $0.0900 \text{ mol dm}^{-3}$ ethanedioic acid, and filled with this acid solution.

Step 3 A pipette is used to transfer 25.0 cm^3 portions of solution J to conical flasks.

Step 4 The portions are titrated with the ethanedioic acid solution using phenolphthalein indicator.

(i) Explain why the burette is rinsed with ethanedioic acid solution in Step 2. (1)

To remove the water, so it doesn't change the concentration of the acid.

(ii) The diagram shows how the student read the filled pipette in Step 3.

Identify the **two** mistakes the student made.

(2)

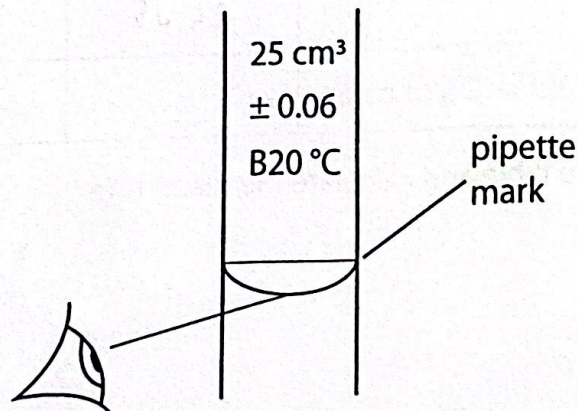

The reading should be taken parallel to the bottom of the meniscus. The ~~meniscus~~ bottom of the meniscus should be at the mark.

(iii) The student completely emptied the pipette for each transfer in Step 3.

Explain the effect on the titre of completely emptying the pipette rather than leaving a small amount of solution in the tip.

(2)

(iv) State the colour change in the conical flask at the end-point.

(2)

From pink to colourless

(c) The titration results are shown.

Titration	1	2	3
Final reading / cm ³	25.05	26.60	25.50
Initial reading / cm ³	✓ 0.00	2.00	1.00
Titre / cm ³	25.05	24.60	24.50
Titres used in calculation of mean		✓	✓

(i) Complete the table and calculate the mean titre.

(2)

$$\begin{array}{r} 24.6 \\ + 24.5 \\ \hline 2 \\ \hline = 24.55 \text{ cm}^3 \end{array}$$

Calculate the concentration of the sodium hydroxide solution in mol dm⁻³.

The equation for the titration is

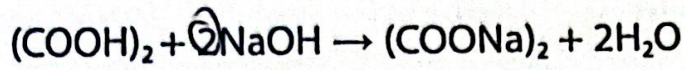

(3)

$$M = \frac{n}{V} \quad \downarrow \quad n: \quad M \times V$$

$$\begin{aligned} n_{(\text{COOH})_2} &= 0.09 \times 0.02455 \\ &= 2.21 \times 10^{-3} \text{ moles} \end{aligned}$$

n NaOH

$$\frac{2.21 \times 10^{-3} \times 2}{x}$$

$$x = 4.419 \times 10^{-3}$$

$$M = \frac{4.419 \times 10^{-3}}{0.025} = 0.17676$$

$$= 0.177 \text{ mol dm}^{-3}$$

(Total for Question 2 = 15 marks)